

## Submersible sludge pump

# SK 155

50 Hz

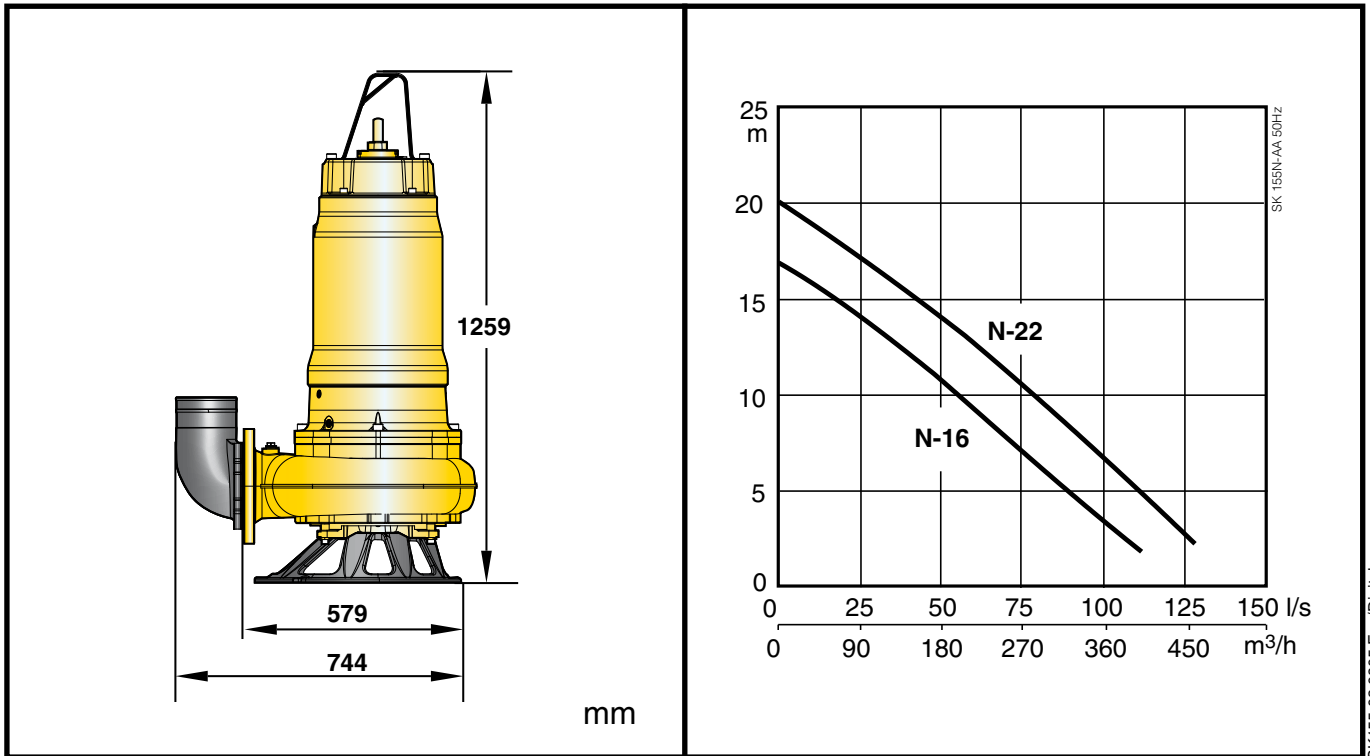

SK155.02.0805.Eng/Digital  
The manufacturer reserves the right to alter performance, specifications or design without notice.

### Specification

Electric submersible sludge pump with a robust ductile iron stand and vortex hydraulic. Free passage 80 mm. Protection class IP 68. Class F insulation. Maximum submergence: 20 m.

### Pump Types

SK 155N-16 3-Phase  
SK 155N-22 3-Phase

### Electric Motor

3-phase squirrel-cage induction motor, 50 Hz

Motor rating  $P_2$ : 16.0 kW (N-16)  
22.0 kW (N-22)

Speed: 1460 rpm (N-16)  
1455 rpm (N-22)

Voltage, V	230	400	500
Nominal current, A (16kW)	53.8	31	24.8
Nominal current, A (22kW)	73.5	42.3	33.8

### Power Cable

20 m type HO7RN-F:  
2x(4G4 + 2x0.75) sq.mm. (230V N-16) (230-400V N-22)  
10G2.5 sq.mm. (400-500V N-16) (500V N-22)

### Motor Protection

Built-in thermal overload sensors. Leakage sensor in the dry chamber indicating presence of water.

### Cooling System

Closed cooling system using water mixed with Glycol (30%).

### Shaft Seal

Double mechanical seal mounted in seal cartridge for easy service.

Primary seal: Silicon carbide on silicon carbide  
Secondary seal: Silicon carbide on carbon

### Bearings

Upper bearing: Single-row deep groove ball bearing  
Lower bearing: Double angular contact ball bearing

### Materials

	EN	ASTM
Motor housing:	Cast iron EN-GJL-250	ASTM A48 35B / 40B
Fasteners:	Stainless steel 10088:X5CrNi18-10 (1.4301)	AISI 304
Rotor shaft:	Stainless steel 10088:X20Cr13 (1.4021)	AISI 420
Volute and impeller:	Cast iron EN-GJL-250	ASTM A48 35B / 40B
Stand:	Nodular cast iron 1563ENGJS-HB150	ASTM A 536-80: 60-40-18

### Discharge Connections

volute DN 150, 6" hose connections.  
G 6" threaded connections

### Weight (without cable)

358 kg (N-16)  
363 kg (N-22)

### Options and Accessories

DOL or Star-Delta start.  
Automatic level control box.  
Zinc anodes.

