

# TD 9-P

Agile, compatto ed affidabile:  
capacità di trasporto, manipolazione  
e molteplicità potenziate al meglio

## Neuson Track Dumper TD 9-P



neuson®



**Motore**

Modello	HONDA GX390 K1 SX
Tipo	motore diesel monocilindrico raffreddato ad aria
Cilindrata / regime d'esercizio	389 ccm/3600 U/min
Potenza max	9,6 kW (13 CV)
Potenza al volano (ISO 3046)	8,7 kW (11,8 CV)
Capacità serbatoio gasolio	6,5 litri



**Impianto idraulico**

Pompa	3 pompe ad ingranaggi
Portata	16,7 + 16,7 + 16,7 l/min
Pressione d'esercizio idraulica di traslazione	175 bar
Pressione d'esercizio idraulica di lavoro	175 bar
Capacità serbatoio olio idraulico	20 litri



**Sistema di traslazione**

2 velocità di traslazione	2,0 e 4,0 km/h
Pendenza max. superabile	30° (58%)
Larghezza cingoli	200 mm
Larghezza carro	800 mm
Numero rulli d'appoggio	3
Altezza libera dal suolo	165 mm



**Cassone**

Volume raso	402 litri
Volume colmo	490 litri
Volume acqua	196 litri
Lunghezza	1135 mm
Larghezza	650 mm
Profondità cassone	540 mm



**Benna autocaricante tipo L (opzione)**

Larghezza	800 mm
max. profondità	130 mm
Lunghezza	2455 mm



**Rumorosità**

Livello di potenza acustica (LWA)	101 dB(A)
Livello di pressione acustica (LPA)	83 dB(A)



**Starter elettrico (standard)**

Batteria	12 V/45 Ah
----------	------------

**Neuson Baumaschinen GmbH**

Haidfeldstraße 37  
A-4060 Linz-Leonding  
Tel. +43 (0)732 90 590-0  
Fax +43 (0)732 90 590-200  
e-Mail [verkauf@neuson.com](mailto:verkauf@neuson.com)  
[www.neusonkramer.com](http://www.neusonkramer.com)

**Kramer-Werke GmbH**

Nußdorfer Straße 50  
D-88662 Überlingen  
Tel. +49(0)7551 802-0  
Fax +49(0)7551 802-260  
e-Mail [info@kramer.de](mailto:info@kramer.de)  
[www.neusonkramer.com](http://www.neusonkramer.com)

**Neuson Ltd.**

Crown Business Park  
Dukestown, Tredegar  
Gwent. NP22 4EF  
United Kingdom  
Tel. +44 (0)1495 72 30 83  
Fax +44 (0)1495 71 39 41  
e-Mail [uksales@neuson.com](mailto:uksales@neuson.com)  
[www.neusonkramer.com](http://www.neusonkramer.com)



**Caratteristiche principali**

Carico utile	900 kg
Peso operativo con benna autocaricante	604 kg
Dimensioni	

a	— Lunghezza	1830 mm
b	— Larghezza	800 mm
c	— Altezza	1350 mm
d	— Altezza pedana	250 mm
e	— Larghezza cingoli	200 mm
h	— Altezza	830 mm
i	— Lunghezza	1135 mm
j	— Larghezza	650 mm
k	— Profondità cassone	540 mm

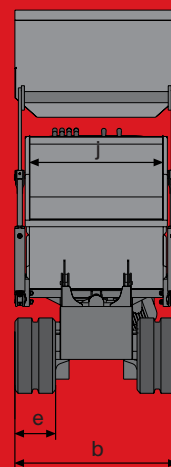
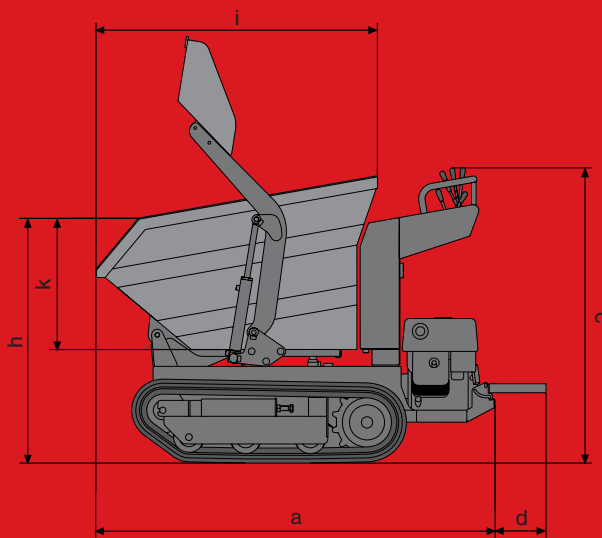

# TD 9-D

Agile, compatto ed affidabile:  
capacità di trasporto, manipolazione  
e molteplicità potenziate al meglio

## Neuson Track Dumper TD9-D



**neuson®**



**Motore**

Modello	YANMAR L100AE-DEVSDYC-4
Tipo	motore diesel monocilindrico raffreddato ad aria
Cilindrata / regime d'esercizio	406 ccm/3600 U/min
Potenza max	7,4 kW (10 CV)
Potenza al volano	
(ISO 3046)	6,6 kW (9 CV)
Batteria	12 V/30 Ah
Capacità serbatoio gasolio	5,4 litri



**Impianto idraulico**

Pompa	3 pompe ad ingranaggi
Portata	16,7 + 16,7 + 16,7 l/min
Pressione d'esercizio idraulica di traslazione	175 bar
Pressione d'esercizio idraulica di lavoro	175 bar
Capacità serbatoio olio idraulico	20 litri



**Sistema di traslazione**

2 velocità di traslazione	2,0 e 4,0 km/h
Pendenza max. superabile	30° (58%)
Larghezza cingoli	200 mm
Larghezza carro	800 mm
Numero rulli d'appoggio	3
Altezza libera dal suolo	165 mm



**Cassone**

Volume raso	402 litri
Volume colmo	490 litri
Volume acqua	196 litri
Lunghezza	1135 mm
Larghezza	650 mm
Profondità cassone	540 mm



**Benna autocaricante tipo L (opzione)**

Larghezza	800 mm
max. profondità	130 mm
Lunghezza	2455 mm



**Rumorosità**

Livello di potenza acustica (LWA)	101 dB(A)
Livello di pressione acustica (LPA)	85 dB(A)



**Starter elettrico (standard)**

**Neuson Baumaschinen GmbH**

Haidfeldstraße 37  
A-4060 Linz-Leonding  
Tel. +43 (0)732 90 590-0  
Fax +43 (0)732 90 590-200  
e-Mail [verkauf@neuson.com](mailto:verkauf@neuson.com)  
[www.neusonkramer.com](http://www.neusonkramer.com)

**Kramer-Werke GmbH**

Nußdorfer Straße 50  
D-88662 Überlingen  
Tel. +49 (0)7551 802-0  
Fax +49 (0)7551 802-260  
e-Mail [info@kramer.de](mailto:info@kramer.de)  
[www.neusonkramer.com](http://www.neusonkramer.com)

**Neuson Ltd.**

Crown Business Park  
Dukestown, Tredegar  
Gwent. NP22 4EF  
United Kingdom  
Tel. +44 (0)1495 72 30 83  
Fax +44 (0)1495 71 39 41  
e-Mail [uksales@neuson.com](mailto:uksales@neuson.com)  
[www.neusonkramer.com](http://www.neusonkramer.com)



**Caratteristiche principali**

Carico utile	900 kg
Peso operativo con benna autocaricante	604 kg
Dimensioni	

a	— Lunghezza	1830 mm
b	— Larghezza	800 mm
c	— Altezza	1350 mm
d	— Altezza pedana	250 mm
e	— Larghezza cingoli	200 mm
h	— Altezza	830 mm
i	— Lunghezza	1135 mm
j	— Larghezza	650 mm
k	— Profondità cassone	540 mm

