

# Neuson Fourwheel drive dumper

## Technical Data

# 3001



### Capacity

	Front Tip
Max. safe load	3000 kg
Unladen weight	2450 kg
Skip - struck	1500 l
- heaped	1850 l
- water level	1160 l



### Engine

Make	Yanmar
Type	3TNV88
	3-cyl, watercooled
Output (Iso 3046/1)	26 (35) kw (hp)
Revolution	2800 min <sup>-1</sup>
Displacement	1642 ccm
Emission	acc. 97/68/EG, step 2



### Drive characteristics

Speed I	0 - 7 km/h
Speed II	0 - 22 km/h
Steering angle	+/- 37 °
Oscillation	+/- 15 °
Turning radius outside	3650 mm
Gradeability	50 %



### Transmission

Final Drive	automotive hydrostatic drive via dropbox to axle and wheels
Steering	hydrostatic center-pivot steering
Tyres	11.50/80-15,3 10 Ply Traction profile
Working brake	foot brake via oil discs in front axle
Parking brake	parking brake via oil discs in front axle



### Hydraulic System

Drive pump	axial piston pump
- flowrate	126 l/min
- oper. press.	360 bar
Working pump	gear pump
- flowrate	45 l/min
- oper. press.	175 bar



### Tank capacity

Diesel	40 l
Hydraulic	48 l



### Electric

Voltage	12 V
Battery	88 Ah
Alternator	40 A
Starter	1,4 kw



### Noise Emission

Noise Level LWA (acc. 2000/14/EC)	101 dB(A)
-----------------------------------	-----------



### Dimension

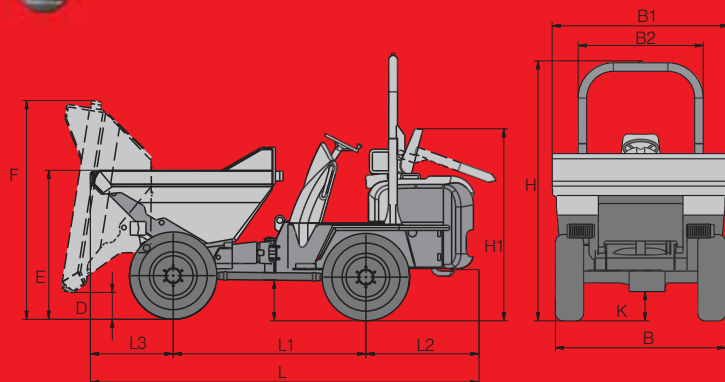

	B	B1	B2	D	E	F	H
mm	1785	1860	1310	260	1475	2220	2670
	H1	K	L	L1	L2	L3	
mm	1870	280	3980	1960	1160	860	



### Features

- Excellent rough terrain performance from hydrost. permanent 4-wheel drive
- Heavy duty construction; skip with 5-8 mm steel plate, reinforced with box sections
- Simple and safe operation; drive direction and speed switch on the steering column.
- Acceleration by foot pedal and braking from hydrost. retardation
- Wide, heavy duty center console protects driver legs
- Simple and clear dashboard including fuel gauge, hourmeter, warning lights for-parking brake, oil filter, oil pressure, engine temperature
- Folding ROPS as standard
- Easy access for service maintenance
- Towing bracket as standard



### Optional equipment

- Road Lights
- Flashing Beacon
- Reversing Alarm
- Spare Wheel
- Turf Profile Tyres
- Biodegradable hydraulic oil
- Trailer socket
- Asphalt skip

Neuson Baumaschinen GmbH  
 Haidfeldstraße 37  
 A-4060 Linz-Leonding  
 Tel. +43 (0) 732 90 590-0  
 Fax +43 (0) 732 90 590-200  
 e-Mail [verkauf@neuson.com](mailto:verkauf@neuson.com)  
[www.neusonkramer.com](http://www.neusonkramer.com)

Neuson Ltd.  
 Crown Business Park,  
 Dukestown, Tredegar,  
 Gwent NP22 4EF  
 United Kingdom  
 Tel +44 (0) 1495 72 30 83  
 Fax +44 (0) 1495 71 39 41  
 e-Mail [uksales@neuson.com](mailto:uksales@neuson.com)  
[www.neusonkramer.com](http://www.neusonkramer.com)

Kramer-Werke GmbH  
 Nußdorfer Straße 50  
 D-88662 Überlingen  
 Tel. +49 (0) 7551 802-0  
 Fax +49 (0) 7551 802-260  
 e-Mail [info@kramer.de](mailto:info@kramer.de)  
[www.neusonkramer.com](http://www.neusonkramer.com)



# Neuson Fourwheel drive dumper

## Technical Data

# 3001s



### Capacity

	Swivel
Max. safe load	3000 kg
Unladen weight	2550 kg
Skip - struck	1300 l
- heaped	1750 l
- water level	900 l
- swing	180-217 °



### Engine

Make	Yanmar
Type	3TNV88
	3-cyl, watercooled
Output (Iso 3046/1)	26 (35) kw (hp)
Revolution	2800 min <sup>-1</sup>
Displacement	1642 ccm
Emission	acc. 97/68/EG, step 2



### Drive characteristics

Speed I	0 - 7 km/h
Speed II	0 - 22 km/h
Steering angle	+/- 37 °
Oscillation	+/- 15 °
Turning radius outside	3650 mm
Gradeability	50 %



### Transmission

Final Drive	automotive hydrostatic drive via dropbox to axle and wheels
Steering	hydrostatic center-pivot steering
Tyres	11.50/80-15,3 10 Ply Traction profile
Working brake	foot brake via oil discs in front axle
Parking brake	parking brake via oil discs in front axle



### Hydraulic System

Drive pump	axial piston pump
- flowrate	126 l/min
- oper. press.	360 bar
Working pump	gear pump
- flowrate	45 l/min
- oper. press.	175 bar



### Tank capacity

Diesel	40 l
Hydraulic	48 l



### Electric

Voltage	12 V
Battery	88 Ah
Alternator	40 A
Starter	1,4 kw



### Noise Emission

Noise Level LWA (acc. 2000/14/EC)	101 dB(A)
-----------------------------------	-----------



### Dimension

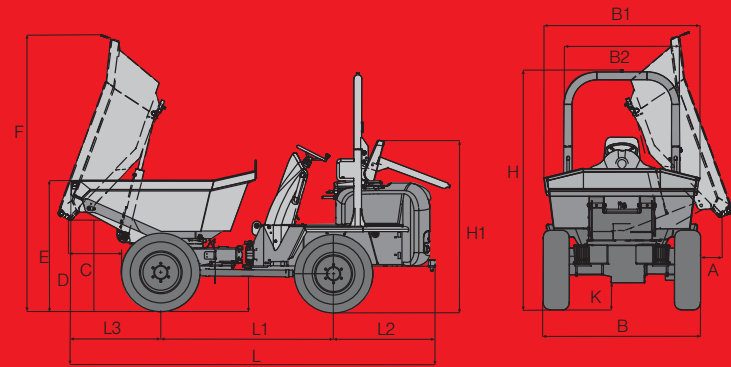

	A	B	B1	B2	C	D	E	F
mm	245	1785	1775	1310	600	1020	1475	3125
	H	H1	K	L	L1	L2	L3	
mm	2670	1870	290	4140	1960	1160	1020	



### Features

- Power swivel skip enabling discharge either side
- Excellent rough terrain performance from hydrost. permanent 4-wheel drive
- Heavy duty construction; skip with 5-8 mm steel plate, reinforced with box sections
- Simple and safe operation; drive direction and speed switch on the steering column.
- Acceleration by foot pedal and braking from hydrost. retardation
- Wide, heavy duty center console protects driver legs
- Simple and clear dashboard including fuel gauge, hourmeter, warning lights for-parking brake, oil filter, oil pressure, engine temperature
- Folding ROPS as standard
- Easy access for service maintenance
- Towing bracket as standard



### Optional equipment

- Road Lights
- Flashing Beacon
- Reversing Alarm
- Spare Wheel
- Turf Profile Tyres
- Biodegradable hydraulic oil
- Trailer socket
- Asphalte skip

Neuson Baumaschinen GmbH  
 Haidfeldstraße 37  
 A-4060 Linz-Leonding  
 Tel. +43 (0) 732 90590-0  
 Fax +43 (0) 732 90590-200  
 e-Mail [verkauf@neuson.com](mailto:verkauf@neuson.com)  
[www.neusonkramer.com](http://www.neusonkramer.com)

Neuson Ltd.  
 Crown Business Park,  
 Duketown, Tredegar,  
 Gwent NP22 4EF  
 United Kingdom

Tel +44 (0) 1495 72 30 83  
 Fax +44 (0) 1495 71 39 41  
 e-Mail [uksales@neuson.com](mailto:uksales@neuson.com)  
[www.neusonkramer.com](http://www.neusonkramer.com)

Kramer-Werke GmbH  
 Nußdorfer Straße 50  
 D-88662 Überlingen  
 Tel. +49 (0) 7551 802-0  
 Fax +49 (0) 7551 802-260  
 e-Mail [info@kramer.de](mailto:info@kramer.de)  
[www.neusonkramer.com](http://www.neusonkramer.com)



We reserve the right to change the above specification w/o prior notice.  
 04/07 - Art.-Nr.: 1000172057



# neuson®