

# Neuson Fourwheel drive dumper

## Technical Data

# 1501



### Capacity

Max. safe load	High tip	1500 kg
Unladen weight		1320 kg
Skip - struck		650 l
- heaped		800 l
- water level		420 l



### Engine

Make	Yanmar	
Type	3TNV76	
	3-cyl, watercooled	
Output (Iso 3046/1)		17 (23,1) kw (hp)
Revolution		3000 min <sup>-1</sup>
Displacement		1116 ccm
Emission	acc. 97/68/EG, step 3A	



### Drive characteristics

Speed	0 - 16 km/h
Steering angle	+/- 33 °
Oscillation	+/- 15 °
Turning radius outside	3300 mm
Gradeability	50 %



### Transmission

Final Drive	hydr. automotive, TWIN-LOCK permanent 4 wheel drive, electo-hydraulic direct.control
Steering	hydrostatic center-pivot steering (load sensing)
Tyres	10.00/75x15 8 Ply Traction profile
Working brake	via foot pedal and wet multidisc in front axle
Parking brake	wet multidisc brake operated by lever in front axle



### Hydraulic System

Drive pump	axial piston pump	
- flowrate		135 l/min
- oper. press.		360 bar
Working pump	gear pump	
- flowrate		25 l/min
- oper. press.		170 bar



### Tank capacity

Diesel	20 l
Hydraulic	20 l



### Electric

Voltage	12 V
Battery	45 Ah
Alternator	40 A
Starter	1,1 kw



### Noise Emission

Noise Level LWA (acc. 2000/14/EC)	101 dB(A)
-----------------------------------	-----------



### Dimension

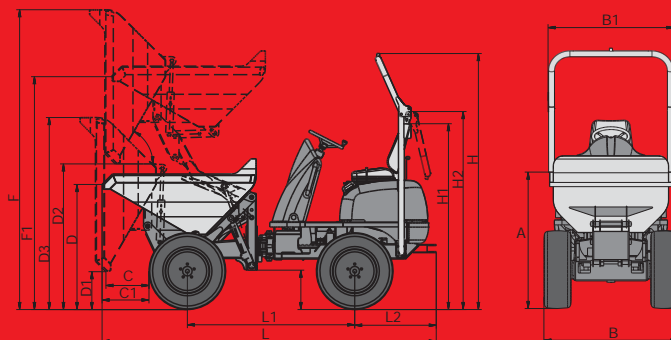

	A	B	B1	C	C1	D	D1	D2	D2
mm	1345	1305	1235	400	440	1240	370	1450 (60°)	1600 (43°)
	D3	F	F1	H	H1	H2	L	L1	L2
mm	1895	2975	2325	2550	1850	1995	3300	1650	810



### Features

- Compact dimensions allows operation in areas with restricted access
- Excellent rough terrain performance from hydrost. permanent 4-wheel drive
- Heavy duty construction; reinforced with box sections
- Simple and safe operation; drive direction switch on the steering column.
- Acceleration by foot pedal and braking from hydrost. retardation
- Wide, heavy duty operator stand protects driver legs
- Simple and clear dashboard including fuel gauge, hourmeter, warning lights for-parking brake, oil filter,oil pressure,engine temperature
- Folding ROPS as standard
- Easy access for service maintenance
- Towing bracket as standard



### Optional equipment

- Flashing Beacon
- Reversing Alarm
- Spare Wheel
- Biodegradeable hydraulic oil
- Awning for control stand and seat
- Road lighting kit
- Rear view mirror

**Wacker Neuson Rhymney Ltd.**  
Crown Business Park, Tredegar  
Gwent South Wales NP22 4EF  
United Kingdom

Tel. +44 (0)1495 72 30 83  
Fax +44 (0)1495 71 39 41

e-Mail [uksales@neuson.com](mailto:uksales@neuson.com)  
[www.wackerneuson.com](http://www.wackerneuson.com)



We reserve the right to change the above specification w/o prior notice.  
08/08 - Art.-Nr.: 1000183559



**neuson**®

# Neuson Fourwheel drive dumper

## Technical Data

# 1501



### Capacity

	Swivel
Max. safe load	1500 kg
Unladen weight	1261 kg
Skip - struck	650 l
- heaped	800 l
- water level	325 l



### Engine

Make	Yanmar
Type	3TNV76
	3-cyl, watercooled
Output (Iso 3046/1)	17 (23,1) kw (hp)
Revolution	3000 min <sup>-1</sup>
Displacement	1116 ccm
Emission	acc. 97/68/EG, step 3A



### Drive characteristics

Speed	0 - 16 km/h
Steering angle	+/- 33 °
Oscillation	+/- 15 °
Turning radius outside	3300 mm
Gradeability	50 %



### Transmission

Final Drive	hydr. automotive, TWIN-LOCK permanent 4 wheel drive, electro-hydraulic direct.control
Steering	hydrostatic center-pivot steering (load sensing)
Tyres	10.00/75x15 8 Ply Traction profile
Working brake	via foot pedal and wet multidisc in front axle
Parking brake	wet multidisc brake operated by lever in front axle



### Hydraulic System

Drive pump	axial piston pump
- flowrate	135 l/min
- oper. press.	360 bar
Working pump	gear pump
- flowrate	25 l/min
- oper. press.	170 bar



### Tank capacity

Diesel	20 l
Hydraulic	20 l



### Electric

Voltage	12 V
Battery	45 Ah
Alternator	40 A
Starter	1,1 kw



### Noise Emission

Noise Level LWA (acc. 2000/14/EC)	101 dB(A)
-----------------------------------	-----------



### Dimension

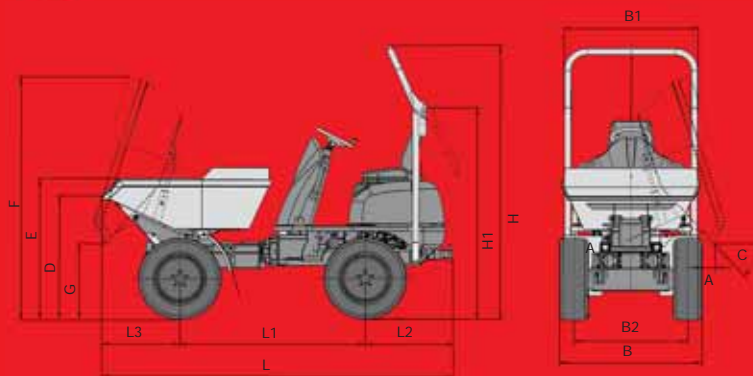

	A	B	B1	B2	C	D	E	F	G
mm	100	1305	1225	1050	47*	1140	1300	2250	680
	H	H1	L	L1	L2	L3			
mm	2550	1960	3220	1700	810	710			



### Features

- Compact dimensions allows operation in areas with restricted access
- Power swivel skip enabling discharge either side
- Excellent rough terrain performance from hydrost. permanent 4-wheel drive
- Heavy duty construction; reinforced with box sections
- Simple and safe operation; drive direction switch on the steering column.
- Acceleration by foot pedal and braking from hydrost. retardation
- Wide, heavy duty operator stand protects driver legs
- Simple and clear dashboard including fuel gauge, hourmeter, warning lights for-parking brake, oil filter,oil pressure,engine temperature
- Folding ROPS as standard
- Easy access for service maintenance
- Towing bracket as standard



### Optional equipment

- Flashing Beacon
- Reversing Alarm
- Spare Wheel
- Biodegradeable hydraulic oil
- Awning for control stand and seat
- Road lighting kit
- Rear view mirror

### Wacker Neuson Rhymney Ltd.

Crown Business Park, Tredgar  
Gwent South Wales NP22 4EF  
United Kingdom

Tel. +44 (0)1495 72 30 83  
Fax +44 (0)1495 71 39 41

e-Mail [uksales@neuson.com](mailto:uksales@neuson.com)  
[www.wackerneuson.com](http://www.wackerneuson.com)



We reserve the right to change the above specification w/o prior notice.  
08/08 - Art.-Nr.: 1000183559



# neuson®